

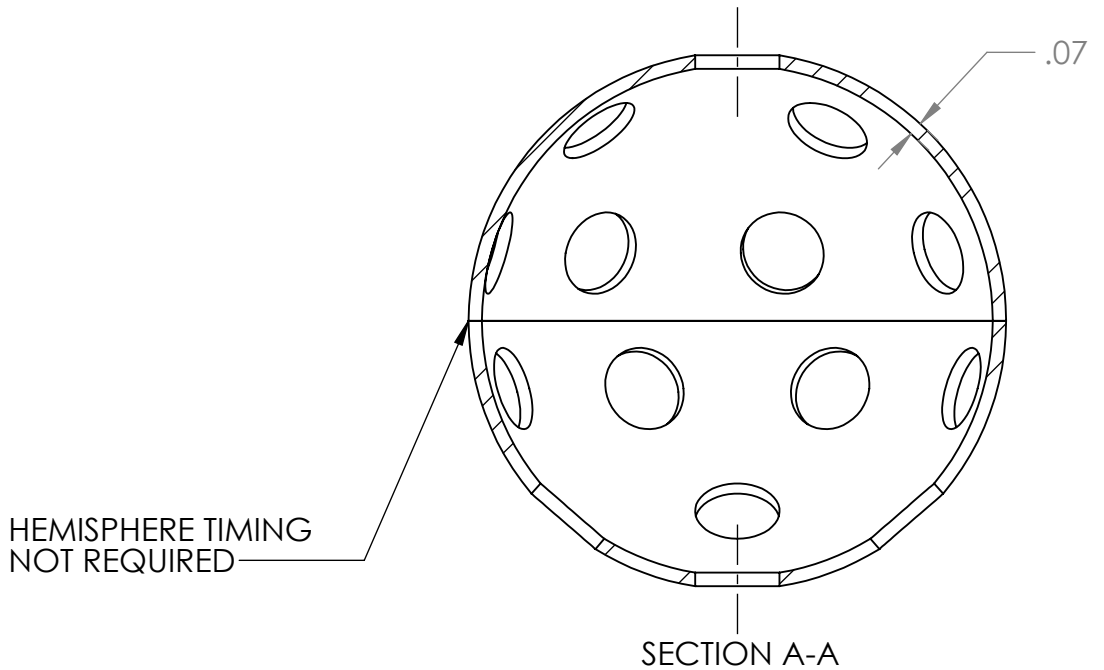

REVISION HISTORY			
REV.	DESCRIPTION	DATE	DRAWN BY
1	ORIGINAL PRINT	4/24/2026	P. YEUNG

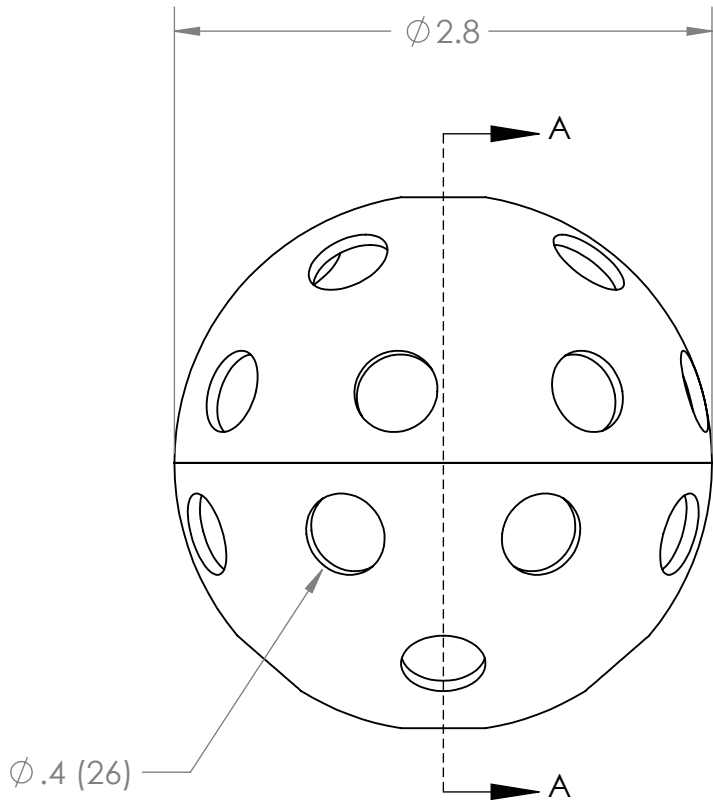

\*\*\* SEE CAD FOR ADDITIONAL TOOLPATH INFO\*\*\*

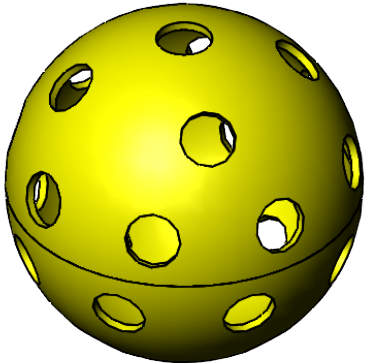

UNLESS OTHERWISE SPECIFIED:		COMMENTS:					
<b>DIMENSIONS ARE IN INCHES</b>		DUAL DIMENSIONS ARE IN MILLIMETERS.					TITLE:
TOLERANCES: FRACTIONAL ±1/16 ANGULAR: MACH ±1° ANGULAR: BEND ±5° ONE PLACE DECIMAL ±0.1 TWO PLACE DECIMAL ±0.01 THREE PLACE DECIMAL ±0.0005 FOUR PLACE DECIMAL ±0.0005		BREAK ALL SHARP EDGES.		POLLEN			
MATERIAL POLYETHYLENE		CHECKED	NAME NM	DATE 4/24/26	SIZE <b>A</b>	DWG. NO. am-5851	REV 1
FINISH		ENG APPR.			SCALE: 1:1		
DO NOT SCALE DRAWING		MFG APPR.			SHEET 1 OF 1		
		Q.A.					